

NOTES:

1. UNLESS OTHERWISE SPECIFIED, TOLERANCES ARE $\pm .010"$ (.254mm).

CAD#321036D2

DRAWING NO.

32-1036

REV.

D

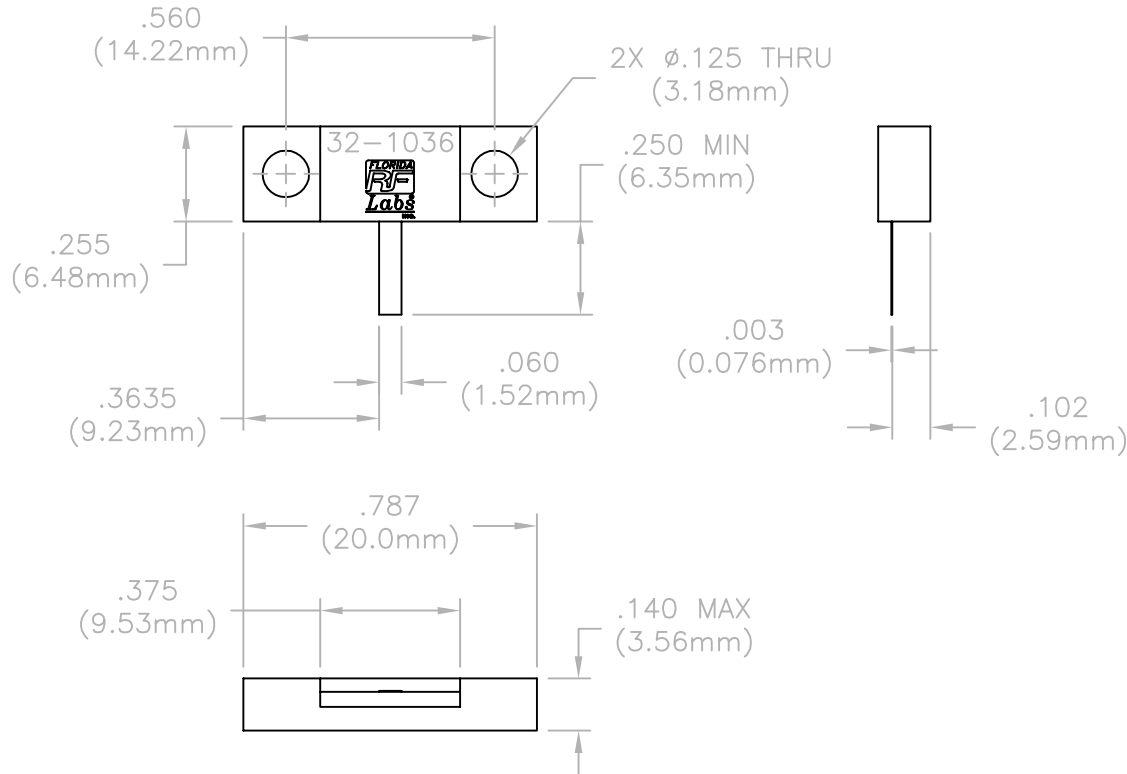

MATERIALS:

MTG FLANGE: COPPER PER ASTM B301
 SUBSTRATE: BERYLLIUM OXIDE
 COVER: ALUMINA OXIDE
 TAB: BERYLLIUM COPPER PER QQ-C-533
 RESISTIVE FILM: NICHROME

FINISH:

MTG FLANGE: NICKEL PER QQ-N-290
 TAB: TIN PER MIL-T-10727

				UNLESS OTHERWISE SPECIFIED 1. DIMENSIONS ARE AFTER PLATING 2. DIAMETERS ON COMMON Q TO BE CONCENTRIC WITHIN ____ T.I.R. 3. SURFACE ROUGHNESS $\sqrt{63}$ 4. CORNERS AND EDGES .005 R. MAX 5. REMOVE BURRS AND BREAK SHARP EDGES	REFERENCE			 P.O. BOX 899 STUART, FL. 34995			
					CATALOG					TITLE	
					MATERIAL			TERMINATION, FLANGE MOUNT, 60 WATT			
					FINISH						
D	DCN#0793	07/98			TOLERANCES			SCALE	CAGE CODE ID NO.	SIZE	DRAWING NO.
C	DCN#0234	09/94	MTG	DECIMAL	FRACTION	ANGLES	2X	2Y194	A	32-1036	D
B	DCN#0195	07/93	MTG	.X \pm			APPR.	CHK	DRAWN	MTG	
A	DCN#0183	01/93	MTG	.XX \pm		\pm ____			01/28/93		
REV.	DESCRIPTION	DATE	APPR.	ALL DIMENSIONS ARE IN INCHES							SHEET 1 OF 2

CAD#321036D3

DRAWING NO.

32-1036

REV

D

REQUIREMENTS	RATING	REQUIREMENTS	RATING
NOMINAL IMPEDANCE (OHMS)	50	VIBRATION	MIL-STD-202 METHOD 204 COND. D (20 G's)
FREQUENCY RANGE (GHz)	DC-6.0		
TEMPERATURE COEFFICIENT	LESS THAN 200 PPM	SHOCK	MIL-STD-202 METHOD 213 COND. I (100 G's)
OPERATING TEMPERATURE (°C)	-55 TO +150		
VSWR	1.20:1	THERMAL SHOCK	MIL-STD-202 METHOD 107 COND. B (-65 TO +125 °C)
AVERAGE POWER (WATTS)	60		
DC RESISTANCE	50 OHMS ± 2%	TERMINAL STRENGTH	MIL-STD-202 METHOD 211 COND. A
		MOISTURE RESISTANCE	MIL-STD-202 METHOD 106 LESS STEP 7B
<p>AVERAGE POWER DERATING</p> <p>% OF RATED PWR</p> <p>CASE TEMPERATURE IN °C</p>		SOLDERABILITY	MIL-STD-202 METHOD 208
			RESISTANCE TO SOLDER HEAT

TITLE

TERMINATION, FLANGE MOUNT
60 WATTP.O. BOX 899
STUART, FL. 34995

DRAWN MTC 01/28/93

SHEET 2 OF 2

DRAWING NO.

32-1036

REV

D