

HITACHI

KAOHSIUNG HITACHI
ELECTRONICS CO.,LTD
P.O. BOX 26-27
2,13TH EAST ST.K.E.P.Z.
KAOHSIUNG TAWAN R.O.C.
TEL:(07) 8211101 (10 LINE)
TELEX 81903 KHE
FAX:(07) 821-5860

FOR MESSRS. ALCATEL

DATE. Jan 28.'00

CUSTOMER'S ACCEPTANCE SPECIFICATIONS

SX19V001-ZZA
C O N T E N T S

| No. | ITEM | SHEET No. | PAGE |
|-----|----------------------------|----------------------------|------------|
| 1 | COVER | 7B64PS 2701-SX19V001-ZZA-8 | 1-1/1 |
| 2 | RECORD OF REVISION | 7B64PS 2702-SX19V001-ZZA-8 | 2-1/3~3/3 |
| 3 | MECHANICAL DATA | 7B64PS 2703-SX19V001-ZZA-8 | 3-1/1 |
| 4 | ABSOLUTE MAXIMUM RATINGS | 7B64PS 2704-SX19V001-ZZA-8 | 4-1/1 |
| 5 | ELECTRICAL CHARACTERISTICS | 7B64PS 2705-SX19V001-ZZA-8 | 5-1/2~2/2 |
| 6 | OPTICAL CHARACTERISTICS | 7B64PS 2706-SX19V001-ZZA-8 | 6-1/3~3/3 |
| 7 | BLOCK DIAGRAM | 7B64PS 2707-SX19V001-ZZA-8 | 7-1/1 |
| 8 | INTERFACE TIMING CHART | 7B64PS 2708-SX19V001-ZZA-8 | 8-1/4~4/4 |
| 9 | DIMENSIONAL OUTLINE | 7B63PS 2709-SX19V001-ZZA-8 | 9-1/2 |
| | | 7B64PS 2709-SX19V001-ZZA-8 | 9-2/2 |
| 10 | APPEARANCE STANDARD | 7B64PS 2710-SX19V001-ZZA-8 | 10-1/7~7/7 |
| 11 | PRECAUTION IN DESIGN | 7B64PS 2711-SX19V001-ZZA-8 | 11-1/3~3/3 |
| 12 | DESIGNATION OF LOT MARK | 7B64PS 2712-SX19V001-ZZA-8 | 12-1/1 |
| 13 | PRECAUTION FOR USE | 7B64PS 2713-SX19V001-ZZA-8 | 13-1/1 |

*WHEN PRODUCT WILL BE DISCONTINUED, CUSTOMER WILL BE INFORMED BY HITACHI WITH TWELVE MONTHS PRIOR ANNOUNCEMENT.

ACCEPTED BY; _____

PROPOSED BY; J. M. Tsai

| | | | | |
|---|------------|----------------------------|------|-------|
| KAOHSIUNG HITACHI ELECTRONICS CO.,LTD. | Sh. No. | 7B64PS 2701-SX19V001-ZZA-8 | PAGE | 1-1/1 |
|---|------------|----------------------------|------|-------|

RECORD OF REVISION

| DATE | SHEET No. | SUMMARY | | | | | | | | | | | | |
|------------|----------------------------|--|-----------------|-----------------|--|-----------------|------|---------|---|----------|----|---------|---|---------|
| Mar.04.'98 | 7B64PS 2703-SX19V001-ZZA-2 | 3.MECMANICAL DATA ADD : (13) :TOUCH SCREEN | | | | | | | | | | | | |
| | 7B64PS 2704-SX19V001-ZZA-2 | 4.1 ELECTRICAL ABSOLUTE MAXMUM RATNGS ADD :TOUCH SCREEN SPEC. | | | | | | | | | | | | |
| | 7B64PS 2705-SX19V001-ZZA-2 | 5.ELECTRICAL CHARACTERISTICS CHANGE :RECOMMENDED LC DRVING VOLTAHE ADD :TOUCH SCREEN SPEC. | | | | | | | | | | | | |
| | 7B64PS 2707-SX19V001-ZZA-2 | ADD :NOTE 2 :NPUT CAPACITANCE. | | | | | | | | | | | | |
| | 7B64PS 2710-SX19V001-ZZA-2 | 10.APPEARANCE STANDARD ADD ;TOUCH SCREEN APPEARANCE. | | | | | | | | | | | | |
| May20.'98 | 7B64PS 2705-SX19V001-ZZA-3 | 5.1 DD & LCD <table style="margin-left: auto; margin-right: auto; border: none;"> <tr> <td></td> <td style="text-align: center;">M N . TYP . MAX</td> <td></td> <td style="text-align: center;">M N . TYP . MAX</td> </tr> <tr> <td>LCD</td> <td style="text-align: center;">- 30 50</td> <td style="text-align: center;">→</td> <td style="text-align: center;">10 20 30</td> </tr> <tr> <td>DD</td> <td style="text-align: center;">- 16 25</td> <td style="text-align: center;">→</td> <td style="text-align: center;">8 16 25</td> </tr> </table> | | M N . TYP . MAX | | M N . TYP . MAX | LCD | - 30 50 | → | 10 20 30 | DD | - 16 25 | → | 8 16 25 |
| | M N . TYP . MAX | | M N . TYP . MAX | | | | | | | | | | | |
| LCD | - 30 50 | → | 10 20 30 | | | | | | | | | | | |
| DD | - 16 25 | → | 8 16 25 | | | | | | | | | | | |
| | 7B64PS 2707-SX19V001-ZZA-3 | ADD :NOTE 2 :NOUT CAPACITANCE CL2-GND=(220PF) (D0~D7)-GND=(5PF) DISP OFF-GND=(5PF) FLM -GND=(0.22μF) | | | | | | | | | | | | |
| | 7B64PS 2708-SX19V001-ZZA-3 | 8.3 POWER ON/OFF SEQUENCE <table style="margin-left: auto; margin-right: auto; border: none;"> <tr> <td></td> <td style="text-align: center;">M N</td> <td></td> <td style="text-align: center;">M N</td> </tr> <tr> <td>DLCS</td> <td style="text-align: center;">20</td> <td style="text-align: center;">→</td> <td style="text-align: center;">100</td> </tr> </table> | | M N | | M N | DLCS | 20 | → | 100 | | | | |
| | M N | | M N | | | | | | | | | | | |
| DLCS | 20 | → | 100 | | | | | | | | | | | |
| | 7B64PS 2709-SX19V001-ZZA-3 | ADD NOTE THE PROTECTIVE FILM WOUKD BE COVERED ON THE TOUCH PANEL. | | | | | | | | | | | | |
| Aug.31.'98 | 7B64PS 2703-SX19V001-ZZA-4 | (13) TPUCH SCREEN MAKER : (DYNAPRO) → (SMK) | | | | | | | | | | | | |
| | 7B64PS 2705-SX19V001-ZZA-4 | 5.ELECTRIC CHARACTER 5.1-1 TOUCH SCREEN SPECIFICATION UPDATE | | | | | | | | | | | | |
| | 7B64PS 2706-SX19V001-ZZA-4 | 6.1 OPTICAL CHARACTERICS OF LCD CONTRAST : (-)M N . → (15)M N . | | | | | | | | | | | | |
| | 7B64PS 2706-SX19V001-ZZA-4 | PAGE6-2/3 CONTRAST : PRICHARD 1980A-PL APERTURE : 0.2° DISTANCE : 0.4m <div style="display: inline-block; vertical-align: middle; font-size: 2em;">}</div> → CONTRAST & | | | | | | | | | | | | |

RECORD OF REVISION

| DATE | SHEET No. | SUMMARY |
|-------------|---|--|
| May 20.'98 | 7B64PS 2709-SX19V001-ZZA-4 | NOTE : TOUCH PANEL TYPE 9442 → MTX0100-5601R (MADE BY DYNAPRO) (MADE BY SMK) |
| | 7B64PS 2709-SX19V001-ZZA-4 | TOUCH PANEL I/F PIN NO. SIGNAL SIGNAL 1 Y (+) Y (-) 2 X (+) X (-) 3 Y (-) Y (+) 4 X (-) X (+) |
| | 7B64PS 2710-SX19V001-ZZA-4 | UPDATE 10.2 (1) LCD ZONE (2) TOUCH PANEL ZONE (3) TOUCH PANEL APPEARANCE |
| Oct 22.'98 | 7B64PS 2709-SX19V001-ZZA-5 PAGE 9-1/2 | 9.1 DIMENSIONAL OUTLINE CHANGE CFL CONNECTOR NUMBER 11.0max → 10.6+/-0.8 ADD STIFFNER SIZE : - → 40 |
| | 7B64PS 2709-SX19V001-ZZA-5 PAGE 9-2/2 | 9.2 INTERNAL PIN CONNECTOR REVISE CFL CONNECTOR PIN NO : 1 ST PIN GND → H.V 4 TH PIN GND → GND |
| | 7B64PS 2710-SX19V001-ZZA-5 PAGE 10-2/7 | UPDATE ALL PAGE |
| Jun. 04.'99 | 7B64PS 2706-SX19V001-ZZA-6 PAGE 6-1/3 | 6. OPTICAL CHARACTERISTICS OF LCD CHANGE COLOR TONE VALUE |
| Jun. 17.'99 | 7B64PS 2706-SX19V001-ZZA-7 PAGE 6-1/3 | 6. OPTICAL CHARACTERISTICS GREEN Y : (0.55)typ → (0.52)typ BLUE Y : (0.14)typ → (0.18)typ WHITE Y : (0.30)typ → (0.31)typ |
| Jun. 23.'99 | 7B64PS 2712-SX19V001-ZZA-7 PAGE 12-1/1 | ADD 12.2 Revision |
| Jan. 28.'00 | 7B64PS 2703-SX19V001-ZZA-8 PAGE 3-1/1 | (13) ADD TOUCH SCREEN MAKER : Fujitsu (PART No N010-0555-T941) |
| | 7B64PS 2705-SX19V001-ZZA-8 PAGE 5-1/2 | 5 ELECTRIC CHARACTER 5.1-1 ADD TOUCH SCREEN SPECIFICATION Rev8.X : 250Ω~750Ω Y : 100Ω~500Ω |

RECORD OF REVISION

| DATE | SHEET No. | SUMMARY |
|------------|---|---|
| Jan 28.'00 | 7B64PS 2709- SX19V001-ZZA-8 PAGE 9-1/2 | NOTE :ADD TOUCH PANEL MADE BY SMKOR Fuitsu. |
| | 7B64PS 2712- SX19V001-ZZA-8 PAGE 12-1/1 | 12.DESIGNATON OF LOT MARK 12.1 LOT MARK OF YEAR UPDATE 12.2 ADD Rev8 REVISION Fuitsu T/P 12.3 LOCATON OF LOT MARK TO WADITY. |
| | | |

3. MECHANICAL DATA

| | |
|------------------------------|---|
| (1) NUMBER OF DOTS | 640 * 3 (R,G,B) (W) * 480 (H) DOTS |
| (2) DOT SIZE | 0.056 (W) mm * 0.214 (H) mm |
| (3) DOT PITCH | 0.079 (W) mm * 0.237 (H) mm |
| (4) MODULE SIZE | 197.0 (W) mm * 145.0 (H) mm * 11.0 mm ax. (D) mm |
| (5) DUTY | 1/480 |
| (6) VIEWING DIRECTION | 6 O'CLOCK |
| (7) DRIVING VOLTAGE | 36.6 TYP (AT25°C) |
| (8) CONTRAST | 25 TYP. (AT25°C) (INCLUDING TOUCH PANEL) |
| (9) RESPONSE TIME (Tr+Tf) | 550 ms (AT25°C) |
| (10) BRIGHTNESS | 60 cd/m ² TYP. (CFL=4.0mA) |
| (11) BACKLIGHT POWER | 1.0 w (EXCEPT INVERTER) • 12FILM TYPE COLOR (NEGATIVE TYPE) • THE UPPER POLARIZER IS GLARE TYPE. THE BUTTOM POLARIZER IS TRANSMISSIVE TYPE. • MAKER :SMK (PART NO NTX0100-5601R) Fujiu (PART NO NO10-0555-T941) |
| (12) LCD | • SIZE :181.0 (W) mm * 143.0 (H) mm • SURFACE :ANTI GLARE HARD COAT, (3H) OPERATING • WITH PEN :0.05~0.3N :PON; SR 0.8mm • WITH FINGER :0.05~0.5N :SILCON RUBBER; φ12, SR 0.8mm |
| (13) TOUCH SCREEN | |

4. ABSOLUTE MAXIMUM RATINGS

4.1 ELECTRICAL ABSOLUTE MAXIMUM RATINGS. VSS=0V STANDARD

| ITEM | | SYMBOL | MIN. | MAX. | UNIT | COMMENT |
|----------------------------|----------------|----------|------|---------|------|--------------------|
| POWER SUPPLY FOR LOGIC | | VDD-VSS | 0 | 7.0 | V | |
| POWER SUPPLY FOR LCD DRIVE | | VLDD-VSS | 0 | 42.0 | V | |
| INPUT VOLTAGE | | V_i | -0.3 | VDD+0.3 | V | NOTE 1 |
| INPUT CURRENT | | I_i | 0 | 1 | A | |
| STATIC ELECTRICITY | | VESD0 | - | +/-100 | V | NOTE 2,3,4 |
| | | VESD1 | - | +/-10 | KV | NOTE 2,3,5 |
| TOUCH SCREEN | VOLTAGE | - | - | 7 | V | DC |
| | CURRENT | - | - | 25 | mA | |
| | OPERATING TEMP | - | 0 | 50 | - | HUMIDITY 20-90% RH |
| | STORAGE TEMP | - | -25 | 70 | - | HUMIDITY 20-95% RH |

NOTE (1) DISPLAY, FLM, CL1, CL2, D0~D7.

NOTE (2): MAKE CERTAIN YOU ARE GROUNDED WHEN HANDLING LCM.

NOTE (3): ENERGY STORAGE CAPACITANCE 200PF, DISCHARGE RESISTANCE 250Ω
Ta=25°C, 60% RH.

NOTE (4): CONTACT DISCHARGE TO I/F CONNECTOR PINS.

NOTE (5): CONTACT DISCHARGE TO FRONT METAL BEZEL.

4.2 ENVIRONMENTAL ABSOLUTE MAXIMUM RATINGS.

| ITEM | OPERATING | | STORAGE | | COMMENT |
|---------------------|----------------|----------------------------------|----------------|--|-----------------------|
| | MIN. | MAX. | MIN. | MAX. | |
| AMBIENT TEMPERATURE | 5°C | 50°C | -20°C | 60°C | NOTE 2,3,7 |
| HUMIDITY | NOTE 1 | | NOTE 1 | | WITHOUT CONDENSATION |
| VIBRATION | - | 2.45m /s ² (0.25G) | - | 11.76m /s ² (1.2G) NOTE 5 | NOTE 4 1 HOUR MAX. |
| SHOCK | - | 29.4m /s ² (3G) | - | 490.0m /s ² (50G) NOTE 5 | XYZ DIRECTIONS |
| CORROSIVE GAS | NOT ACCEPTABLE | | NOT ACCEPTABLE | | |

NOTE (1) Ta<=40°C 85% RH max.

Ta>40°C ABSOLUTE HUMIDITY MUST BE LOWER THAN THE HUMIDITY OF 85% RH AT 40°C.

NOTE (2) Ta AT -20°C ——< 48HRS AT 60°C ——< 168HRS.

NOTE (3) BACKGROUND COLOR CHANGES SLIGHTLY DEPENDING ON AMBIENT TEMPERATURE. THIS PHENOMENON IS REVERSIBLE.

NOTE (4) 5Hz; 100Hz (EXCEPT RESONANCE FREQUENCY)

NOTE (5) THIS MODULE SHOULD BE OPERATED NORMALLY AFTER FINISH THE TEST.

NOTE (6) WHEN LCM WILL BE OPERATED AT 5°C, THE LIFE TIME OF CFL WILL BE REDUCED. NEED TO MAKE SURE OF VALUE OF IL AND CHARACTERISTICS OF INVERTER. ALSO THE RESPONSE TIME AT 5°C WILL BE SLOWER.

NOTE (7) THERE ARE POSSIBILITY THAT COLOR UN-UNIFORMITY HAPPENED WHILE OPERATION AT 50°C.

5. ELECTRICAL CHARACTERISTICS

5.1 ELECTRICAL CHARACTERISTICS OF LCD

| ITEM | SYMBOL | CONDITION | MIN. | TYP. | MAX. | UNIT |
|--|----------|--------------------------------|--------|------|--------|------|
| POWER SUPPLY VOLTAGE FOR LOGIC | VDD-VSS | - | 3.15 | 3.3 | 5.15 | V |
| POWER SUPPLY VOLTAGE FOR LC DRIVING | VLCD-VSS | - | - | - | 40 | V |
| INPUT VOLTAGE NOTE 1 | VI | H LEVEL | 0.8VDD | - | VDD | V |
| | | L LEVEL | 0 | - | 0.2VDD | V |
| INPUT LEAK CURRENT NOTE 2 | Ih | VM=VCC or GND Ta=25°C | - | - | +/-0.1 | μA |
| POWER SUPPLY CURRENT FOR LC DRIVING NOTE 2 | ILCD | VDD-VSS=3.3V VLCD-VSS=36.6V | 10 | 20 | 30 | mA |
| POWER SUPPLY CURRENT FOR LOGIC CURRENT NOTE 2 | IDD | VDD-VSS=3.3V VLCD-VSS=36.6V | 8 | 16 | 25 | mA |
| RECOMMENDED LC DRIVING VOLTAGE NOTE 3 | VLCD-VSS | Ta= 5°C φ=0° | - | 37.6 | - | V |
| | | Ta=25°C ,φ=0° | - | 36.6 | - | V |
| | | Ta=40°C .φ=0° | - | 35.6 | - | V |
| FRAME FREQUENCY NOTE 4 | fFLM | VDD>3.15V | 70 | 120 | (140) | Hz |

NOTE 1 DISP.OFF ,FLM ,CL1 ,CL2 ,D0~D7.

NOTE 2 fFLM=75HZ ,TEST PATTERN IS ALL "Q" .
VLCD-VSS=36.6V,Ta=25°C .

NOTE 3 RECOMMENDED LC DRIVING VOLTAGE FLUCTUATE ABOUT +/-1.0V BY EACH MODULE..
TEST PATTERN IS ALL "Q" .

NOTE 4 NEED TO MAKE SURE OF FLICKERING AND RIPPLING OF DISPLAY WHEN SETTING THE FRAME FREQUENCY IN YOUR SET.

5.1-1 TOUCH SCREEN

| ITEM | SPECIFICATIONS | REMARKS |
|-------------------------|---|----------|
| VOLTAGE | 5VDC | |
| CURRENT | <10 mA | |
| LEAD TO LEAD RESISTANCE | Rev.7 X : 400Ω~900Ω Y : 250Ω~700Ω | |
| | Rev.8 X : 250Ω~750Ω Y : 100Ω~500Ω | |
| INSULATION RESISTANCE | >25M Ω@ 25VDC | |
| CONTACT BOUNCE | <10 ms | NOTE (1) |

NOTE (1) : HIT ANY POINT WITHIN THE EFFECTIVE AREA IN A NORMAL MANNER (2 TO 3 HITS A SECOND WITH A FORCE OF ABOUT 2N)

5.2 ELECTRICAL CHARACTERISTICS OF BACKLIGHT

| ITEM | SYMBOL | MIN. | TYP. | MAX. | UNIT | NOTE |
|----------------------------|--------------|--------|-------|-------|------------------|---------|
| LAMP VOLTAGE | VL | - | (450) | - | V _{rms} | Ta=25°C |
| FREQUENCY | fL | (60) | (70) | (85) | KHz | |
| LAMP CURRENT | IL | (3.5) | (4.0) | (5.0) | mA | Ta=25°C |
| STARTING DISCHARGE VOLTAGE | VS NOTE 2 | (1400) | - | - | V _{rms} | Ta=5°C |

NOTE 1 PLEASE DESIGN YOUR LAMP DRIVING CIRCUIT (INVERTER) ACCORDING TO THE ABOVE SPECIFICATIONS AND INFORM HITACHI OF IT.

NOTE 2 STARTING DISCHARGE VOLTAGE IS INCREASED WHEN LCM IS OPERATING AT LOWER TEMPERATURE. PLEASE CHECK THE CHARACTERISTICS OF YOUR INVERTER BEFORE APPLYING TO YOUR SET.

NOTE 3 AVERAGE LIFE TIME OF CFL WILL BE DECREASED WHEN LCM IS OPERATING AT LOWER TEMPERATURE.

NOTE 4 UNDER LOWER DRIVING FREQUENCY OF AN INVERTER, A CERTAIN BACKLIGHT SYSTEM (CFL & CFL REFLECTION SHEET) MAY GENERATE A SOUND NOISE BEFORE DESIGNING THE INVERTER.

NOTE 5 WHEN CFL IS USED OVER 5.0mA, IT MAY CAUSE UNEVEN CONTRAST NEAR CFL LOCATION, DUE TO HEAT DISPERSION FROM CFL.

NOTE 6 SUITABLE INVERTER INVC445.

6. OPTICAL CHARACTERISTICS

6.1 OPTICAL CHARACTERISTICS OF LCD

Ta=25°C (BACKLIGHT ON)

| ITEM | | SYMBOL | CONDITION | MIN. | TYP. | MAX. | UNIT | NOTE |
|-------------------------------|-------|-----------------|-------------------------------|--------|--------|--------|------|-------|
| VIEWING AREA | | $\phi 2-\phi 1$ | $\theta=0^\circ, K \geq 2.0$ | - | 40 | - | deg | 1,2 |
| CONTRAST RATIO | | K | $\phi=0^\circ \theta=0^\circ$ | - | 25 | - | - | 3,5,6 |
| RESPONSE TIME (RISE) | | tr | $\phi=0^\circ \theta=0^\circ$ | - | 350 | - | ms | 4 |
| RESPONSE TIME (FALL) | | tf | $\phi=0^\circ \theta=0^\circ$ | - | 200 | - | ms | 4 |
| COLOR TONE (PRIMARY COLOR) | RED | x | $\phi=0^\circ \theta=0^\circ$ | (0.52) | (0.57) | (0.62) | - | 7 |
| | | y | | (0.28) | (0.33) | (0.38) | - | |
| | GREEN | x | | (0.27) | (0.32) | (0.37) | - | |
| | | y | | (0.47) | (0.52) | (0.57) | - | |
| | BLUE | x | | (0.12) | (0.17) | (0.22) | - | |
| | | y | | (0.13) | (0.18) | (0.23) | - | |
| | WHITE | x | | (0.26) | (0.31) | (0.36) | - | |
| | | y | | (0.26) | (0.31) | (0.36) | - | |

(MEASUREMENT CONDITION ; HITACHI STANDARD)

NOTE 1 DEFINITION OF θ AND ϕ
(NORMAL)
VIEWING DIRECTION 2

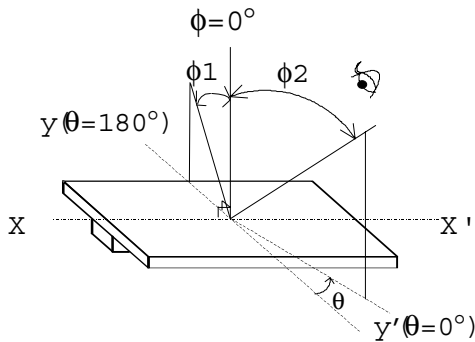

NOTE 3 DEFINITION OF CONTRAST "K"
$$K = \frac{\text{BRIGHTNESS ON SELECTED DOT (B1)}}{\text{BRIGHTNESS ON NON-SELECTED DOT (B2)}}$$

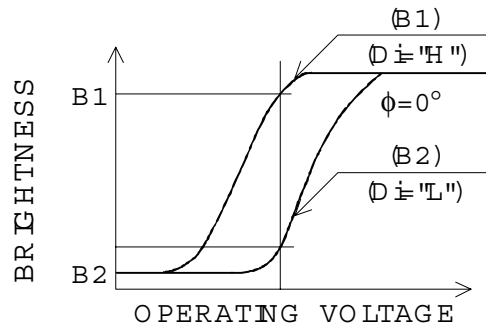

NOTE 2 DEFINITION OF VIEWING ANGLE
 ϕ_1 AND ϕ_2
 $(-40^\circ) < \phi_1 < 0^\circ < \phi_2 < (40^\circ)$

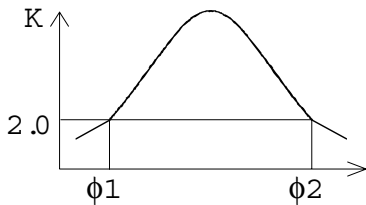

CONTRAST RATIO K VS VIEWING ANGLE ϕ .

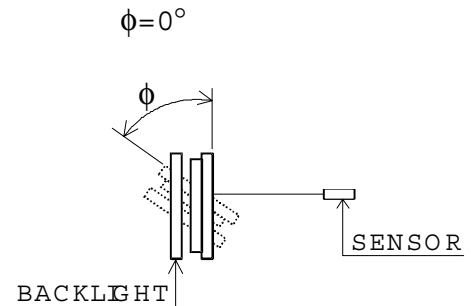

CONTRAST : BM -7
APERTURE : 1°
DISTANCE : 0.4m
BRIGHTNESS BM -7
APERTURE : 1°
DISTANCE : 0.4m

NOTE 4 DEFINITION OF OPTICAL RESPONSE TIME

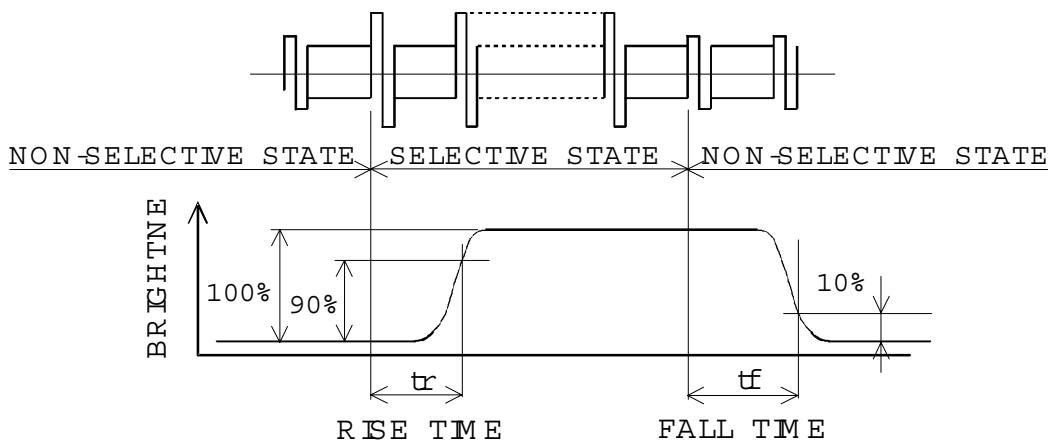

NOTE 5. HITACHI WILL NOT DO 100% INSPECTION FOR MINIMUM VALUE.
MINIMUM VALUE IS FOR REFERENCE.
NOTE 6. HITACHI WILL DO SAMPLING INSPECTION FOR MINIMUM VALUE.
NOTE 7. THE LCD DRIVING VOLTAGE SHOULD BE ADJUSTED AT THE
VOLTAGE WHERE THE PEAK CONTRAST IS OBTAINED.

6.2 OPTICAL CHARACTERISTICS OF BACKLIGHT

| ITEM | MIN. | TYP. | MAX. | UNIT | NOTE |
|-----------------------|------|------|-------|-------------------|----------------------------|
| BRIGHTNESS | 45 | 65 | - | cd/m ² | IL=4.0mA NOTE 1,2 |
| RISE TIME | - | 3 | - | MINUTE | IL=4.0mA BRIGHTNESS 80% |
| BRIGHTNESS UNIFORMITY | - | - | +/-30 | % | UNDERMENTIONED NOTE 1,3 |

(MEASUREMENT CONDITION HITACHI STANDARD)

CFL: INITIAL, Ta=25°C, THE LCD DRIVING SHOULD BE ADJUSTED AT VOLTAGE WHERE THE PEAK CONTRAST IS OBTAINED, WHEN SET PATTERN IS ALL "Q" DISPLAY DATA SHOULD BE ALL "ON".

NOTE 1 MEASUREMENT AFTER 10 MINUTES OF CFL OPERATING.
MEASUREMENT CONDITION: SEE NOTE 3 ON PAGE 6-1/2.

NOTE 2 BRIGHTNESS CONTROL: 100%.

NOTE 3 MEASUREMENT OF THE FOLLOWING 9 PLACES ON THE DISPLAY.
DEFINITION OF THE BRIGHTNESS TOLERANCE.

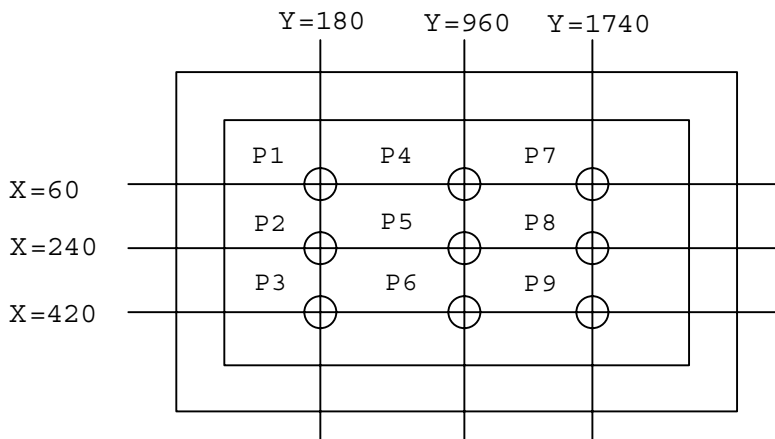

$$\left(\frac{\text{MAX BRIGHTNESS OR MIN BRIGHTNESS} - \text{AVERAGE BRIGHTNESS}}{\text{AVERAGE BRIGHTNESS}} \right) \times 100$$

7. BLOCK DIAGRAM

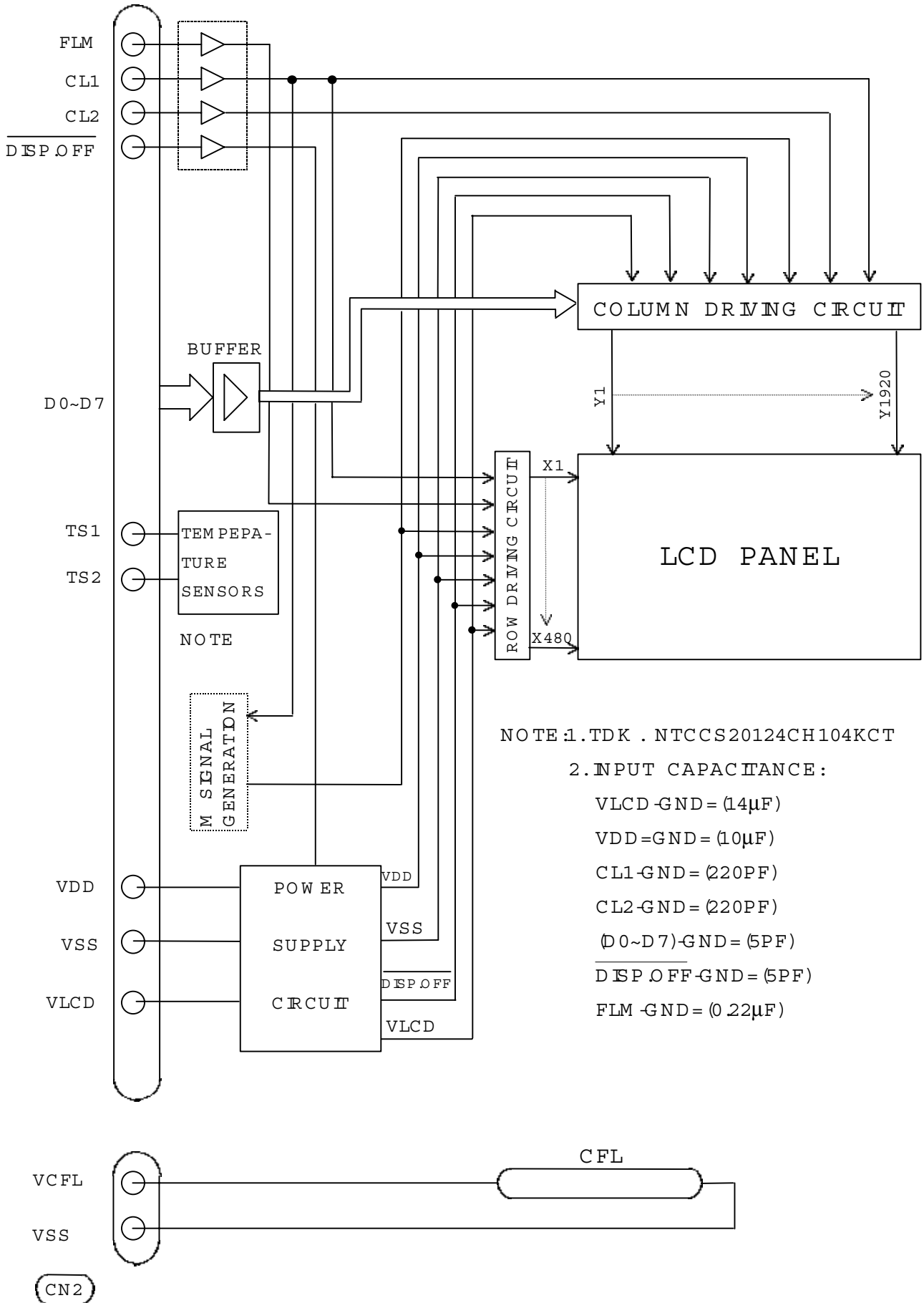

NOTE 1. TDK . NTCCS20124CH104KCT

2. INPUT CAPACITANCE :

VLCD-GND = (14 μ F)

VDD-GND = (10 μ F)

CL1-GND = (220PF)

CL2-GND = (220PF)

(D0~D7)-GND = (5PF)

DISP OFF-GND = (5PF)

FLM-GND = (0.22 μ F)

8. INTERFACE TIMING CHART

8.1 TIMING CHART

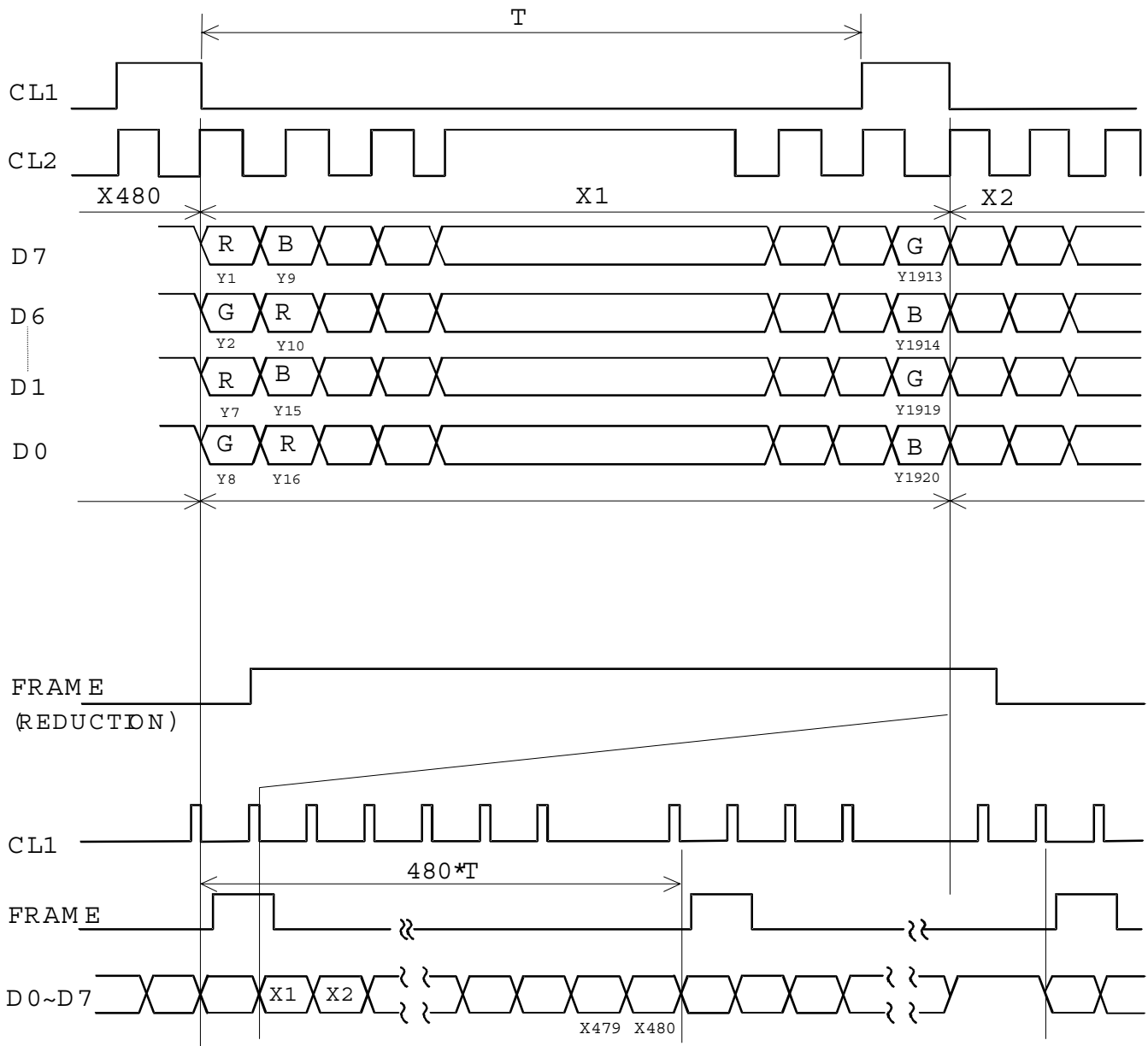

8.2 INTERFACE TIMING SPECIFICATION

(VDD=3.15~5.5V)

| ITEM | SYMBOL | MIN. | TYP. | MAX. | UNIT |
|---------------------|--------------------------|------|------|----------------|------|
| CL1 PULSE WIDTH "H" | t_{WHCL1} | 30 | - | - | ns |
| CLOCK FREQUENCY | f_{cp} VDD=3.15~5.5V | - | - | 16.6 | MHz |
| CL2 PULSE WIDTH | t_{WCL2} | 25 | - | - | ns |
| CLOCK SET UP TIME | t_{SCL1} | 100 | - | - | ns |
| CLOCK HOLD TIME | t_{HCL1} | 100 | - | - | ns |
| CLOCK RISE UP TIME | t_r, t_f | - | - | 50 NOTE (1) | ns |
| DATA SET UP TIME | t_{DSU} | 20 | - | - | ns |
| DATA HOLD TIME | t_{DH} | 25 | - | - | ns |
| "FRAME" SET UP TIME | t_{FS} | 100 | - | - | ns |
| "FRAME" HOLD TIME | t_{FH} | 30 | - | - | ns |
| "M" DELAY TIME | t_M | - | - | 300 | ns |

NOTE 1 : (1) $t_r, t_f = \frac{1/f_{cp} - 2t_{WCL2}}{2}$ (2) $t_r, t_f = 50ns$

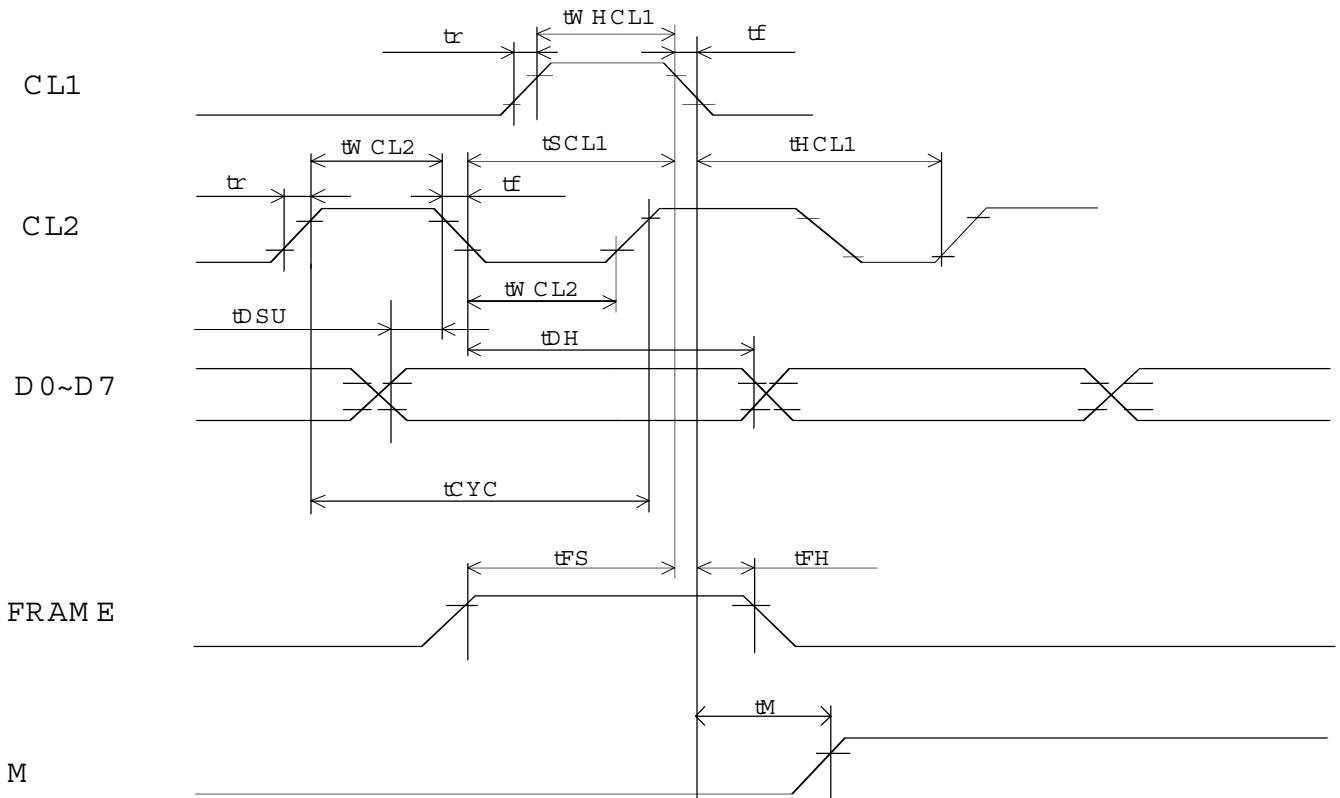

8.3 POWER ON/OFF SEQUENCE

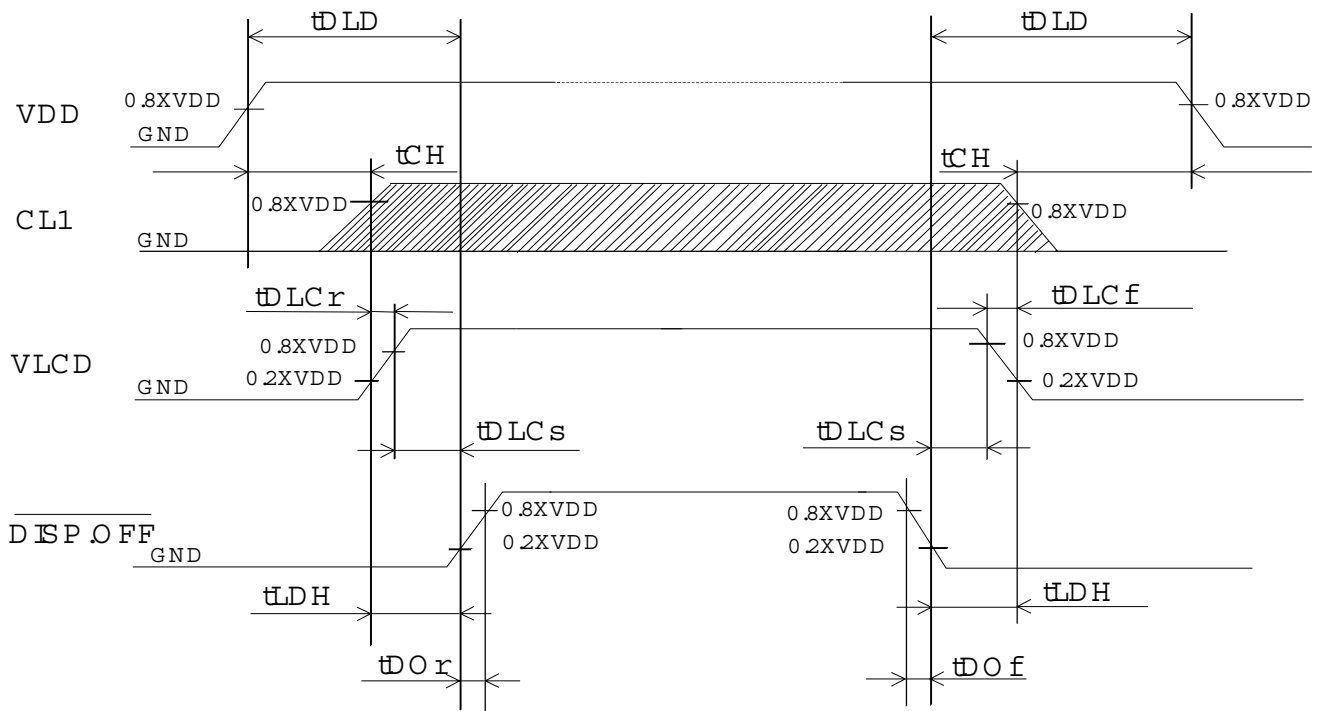

| SYMBOL | MIN | MAX | UNIT | COMMENT |
|--------|-----|-----|------|----------|
| tDL | 200 | - | ms | (NOTE 1) |
| tCH | 0 | 200 | ms | |
| tLDH | 0 | - | ms | |
| tOr | - | 100 | ns | (NOTE 2) |
| tOf | - | 100 | ns | |
| tLDCr | 0 | - | ms | |
| tLDCf | 0 | - | ms | |
| tLDCs | 100 | - | ms | |

(NOTE 1) PLEASE KEEP THE SPECIFIED SEQUENCE BECAUSE WRONG SEQUENCE MAY CAUSE PERMANENT DAMAGE TO THE LCD PANEL.

(NOTE 2) HITACHI RECOMMENDS YOU TO USE DISP OFF FUNCTION. DISPLAY QUALITY MAY DETERIORATE IF YOU DON'T USE DISP OFF FUNCTION.

8.4 POWER SUPPLY FOR LCM (EXAMPLE)

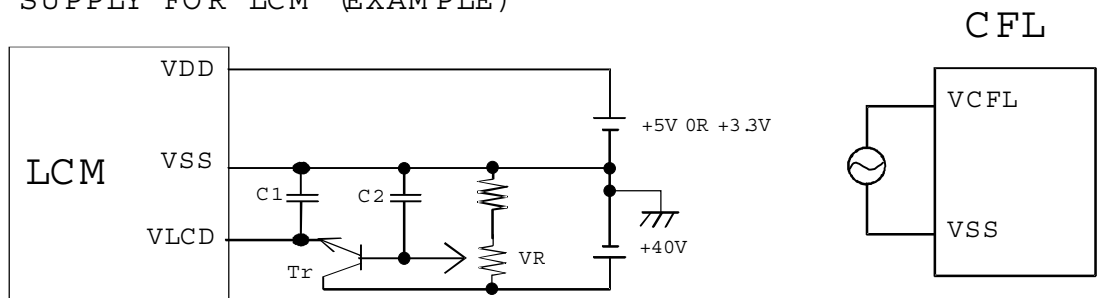

NOTE 1 VR : 10kΩ
 C1 : 10 μ μF
 C2 : 3.3μF
 Tr: Ic(PEEK)SHOULD BE LARGER THAN 1A (PEEK)x25m s

8.5 DATA RESPOND

| DATA SIGNAL | D 7 | D 6 | D 5 | D 4 | D 3 | D 2 | D 1 | D 0 | D 7 | D 6 | D 5 | D 4 | --- | D 4 | D 3 | D 2 | D 1 | D 0 |
|-------------|-----|-----|-----|-----|-----|-----|-----|-----|-----|-----|-----|-----|-----|-----|-----|-----|-----|-----|
| Y | 1 | 2 | 3 | 4 | 5 | 6 | 7 | 8 | 9 | 10 | 11 | 12 | --- | 1 | 1 | 1 | 1 | 1 |
| X | | | | | | | | | | | | | --- | 9 | 9 | 9 | 9 | 9 |
| | | | | | | | | | | | | | | 1 | 1 | 1 | 1 | 2 |
| | | | | | | | | | | | | | | 6 | 7 | 8 | 9 | 0 |
| 1 | R | G | B | R | G | B | R | G | B | R | G | B | | G | B | R | G | B |
| 2 | R | G | B | R | G | B | R | G | B | R | G | B | | G | B | R | G | B |
| 3 | R | G | B | R | G | B | R | G | B | R | G | B | | G | B | R | G | B |
| 4 | R | G | B | R | G | B | R | G | B | R | G | B | | G | B | R | G | B |
| 5 | R | G | B | R | G | B | R | G | B | R | G | B | | G | B | R | G | B |
| . | . | . | . | . | . | . | . | . | . | . | . | . | | . | . | . | . | . |
| . | . | . | . | . | . | . | . | . | . | . | . | . | | . | . | . | . | . |
| . | . | . | . | . | . | . | . | . | . | . | . | . | | . | . | . | . | . |
| 238 | R | G | B | R | G | B | R | G | B | R | G | B | | G | B | R | G | B |
| 239 | R | G | B | R | G | B | R | G | B | R | G | B | | G | B | R | G | B |
| 240 | R | G | B | R | G | B | R | G | B | R | G | B | | G | B | R | G | B |
| 241 | R | G | B | R | G | B | R | G | B | R | G | B | | G | B | R | G | B |
| 242 | R | G | B | R | G | B | R | G | B | R | G | B | | G | B | R | G | B |
| 243 | R | G | B | R | G | B | R | G | B | R | G | B | | G | B | R | G | B |
| 244 | R | G | B | R | G | B | R | G | B | R | G | B | | G | B | R | G | B |
| 245 | R | G | B | R | G | B | R | G | B | R | G | B | | G | B | R | G | B |
| . | . | . | . | . | . | . | . | . | . | . | . | . | | . | . | . | . | . |
| . | . | . | . | . | . | . | . | . | . | . | . | . | | . | . | . | . | . |
| . | . | . | . | . | . | . | . | . | . | . | . | . | | . | . | . | . | . |
| 478 | R | G | B | R | G | B | R | G | B | R | G | B | | G | B | R | G | B |
| 479 | R | G | B | R | G | B | R | G | B | R | G | B | | G | B | R | G | B |
| 480 | R | G | B | R | G | B | R | G | B | R | G | B | | G | B | R | G | B |

R :RED
 G :GREEN
 B :BLUE

9.1 DIMENSIONAL OUTLINE

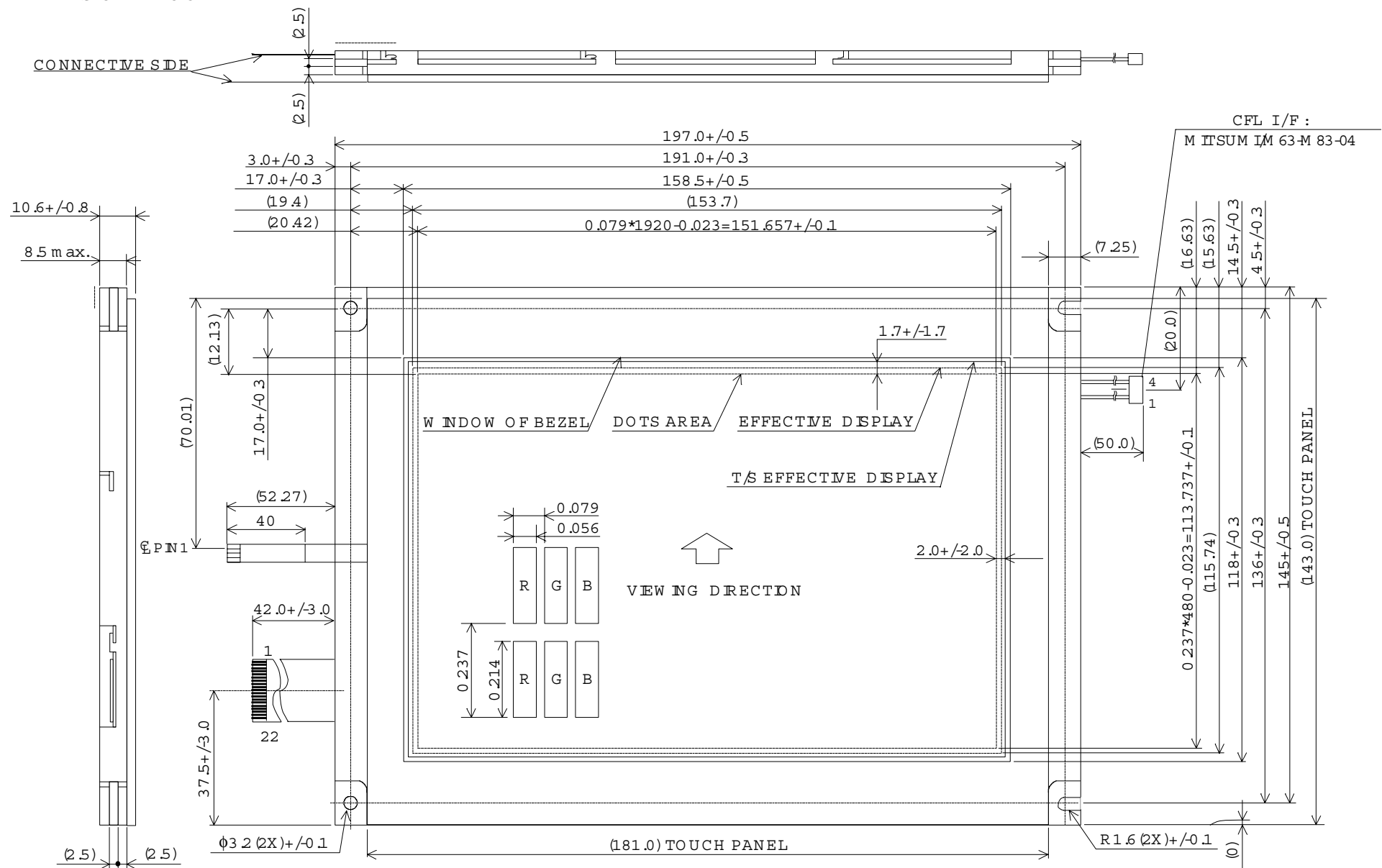

NOTE :FPC PITCH :1.0mm .
 SUITABLE CONNECTOR :L-402-22S-S1L-SA (MAKER JAE)
 TOUCH PANEL MADE BY SMK OR SMK,Fujitsu.
 THE PROTECTIVE FILM WOULD BE COVERED ON THE TOUCH PANEL

| | | | | | | |
|---|------|-----------|------------|----------------------------|------|-------|
| KAOSHUNG HITACHI ELECTRONICS CO.,LTD | Date | Jan.28.00 | Sh. No. | 7B63PS 2709-SX19V001-ZZA-8 | Page | 9-1/2 |
|---|------|-----------|------------|----------------------------|------|-------|

9.2 INTERNAL PN CONNECTION

FPC : PITCH 1.0mm

SUITABLE CONNECTOR : L-402-22S-S1L-SA (MAKER :JAE)

| PN No. | SIGNAL | LEVEL | FUNCTION |
|--------|----------|-------|------------------------|
| 1 | FLM | H | FRST LINE MARKER |
| 2 | VSS | - | GND |
| 3 | CL1 | H→L | DATA LATCH |
| 4 | VSS | - | GND |
| 5 | CL2 | H→L | DATA SHIFT |
| 6 | VSS | - | GND |
| 7 | D0 | H/L | DISPLAY DATA |
| 8 | D1 | | |
| 9 | D2 | | |
| 10 | D3 | | |
| 11 | D4 | | |
| 12 | D5 | | |
| 13 | D6 | | |
| 14 | D7 | | |
| 15 | DISP OFF | H/L | H ON / L OFF |
| 16 | VDD | - | POWER SUPPLY FOR LOGIC |
| 17 | VDD | - | POWER SUPPLY FOR LOGIC |
| 18 | VSS | - | GND |
| 19 | VLCD | - | POWER SUPPLY FOR LC |
| 20 | VSS | - | GND |
| 21 | TS1 | - | TEMPERATURE SENSOR PN1 |
| 22 | TS2 | - | TEMPERATURE SENSOR PN2 |

CFL I/F : MITSUMI M63-M83-04

SUITABLE CONNECTOR MITSUMI M61M73-04

MITSUMI M60-04-30-114P (STRAIGHT)

MITSUMI M60-04-30-134P (ANGLE)

| PN No. | SIGNAL | LEVEL | FUNCTION |
|--------|--------|-------|----------------------|
| 1 | HV | - | POWER SUPPLY FOR CFL |
| 2 | N.C | - | - |
| 3 | N.C | - | - |
| 4 | GND | - | CFL GND |

TOUCH PANEL I/F

| PN No. | SIGNAL | LEVEL | FUNCTION |
|--------|--------|-------|----------|
| 1 | Y (-) | - | TOP |
| 2 | X (-) | - | LEFT |
| 3 | Y (+) | - | BOTTOM |
| 4 | X (+) | - | RIGHT |

10. APPEARANCE STANDARD

10.1 APPEARANCE INSPECTION CONDITION

VISUAL INSPECTION SHOULD BE DONE UNDER THE FOLLOWING CONDITION.

- (1) THE INSPECTION SHOULD BE DONE IN A DARK ROOM.
- (2) THE CFL SHOULD BE LIGHTED WITH THE PRESCRIBED INVERTER.
- (3) THE DISTANCE BETWEEN EYES OF AN INSPECTOR AND THE LCD MODULE IS 25cm.
- (4) THE VIEWING ZONE IS SHOWN THE FIGURE.
VIEWING ANGLE $\leq 25^\circ$.

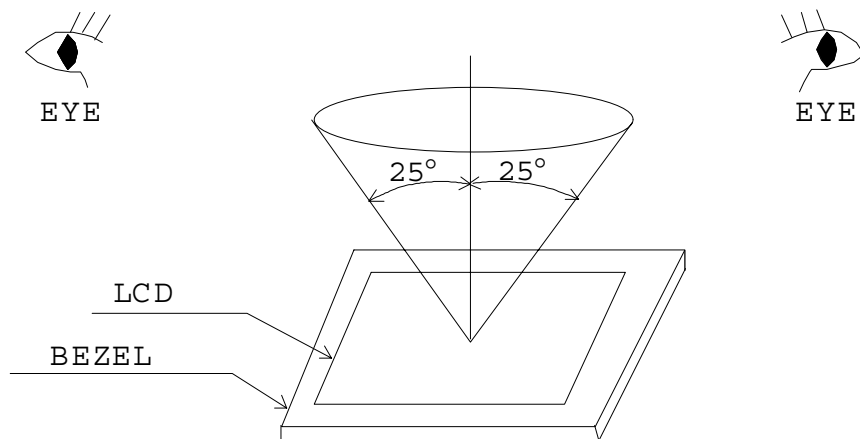

10.2 DEFINITION OF ZONE

(1) LCD ZONE

A ZONE : WITHIN THE EFFECTIVE AREA SPECIFIED AT PAGE 9-1/1 OF THIS DOCUMENT.

B ZONE : AREA BETWEEN THE EDGE LINE OF LCD CELL AND THE EFFECTIVE DISPLAY AREA (A ZONE) LINE SPECIFIED AT PAGE 9-1/1 OF THIS DOCUMENT.

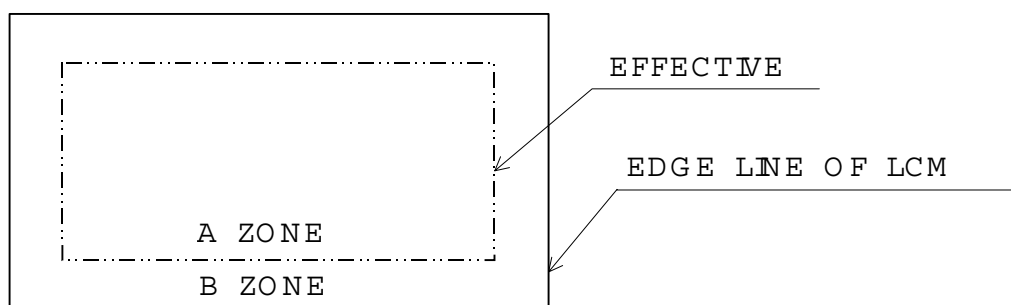

(2) TOUCH PANEL ZONE

(2-1) X ZONE (ACTIVE AREA):

(1) AREA TO BE GUARANTEED ALL CHARACTERISTICS STATED ON THIS SPEC.

(2) LCD DOT AREA MUST BE DESIGNED NOT TO EXCEED THESE DIMENSION. (1.5mm OR GREATER PER SIDE IS DESIRABLE)

(2-2) Y ZONE (VIEWING AREA)

IT'S ELECTRICITY CONDUCTIVE, BUT NOT TO QUARANTELL LINEARITY.

(2-3) Z ZONE (ISOLATED AREA)

AN AREA PROVIDED FOR LAYING ELECTRODES AND PATTEN ACCEPTS RESIST PRINTING AND ADHENSIVE.

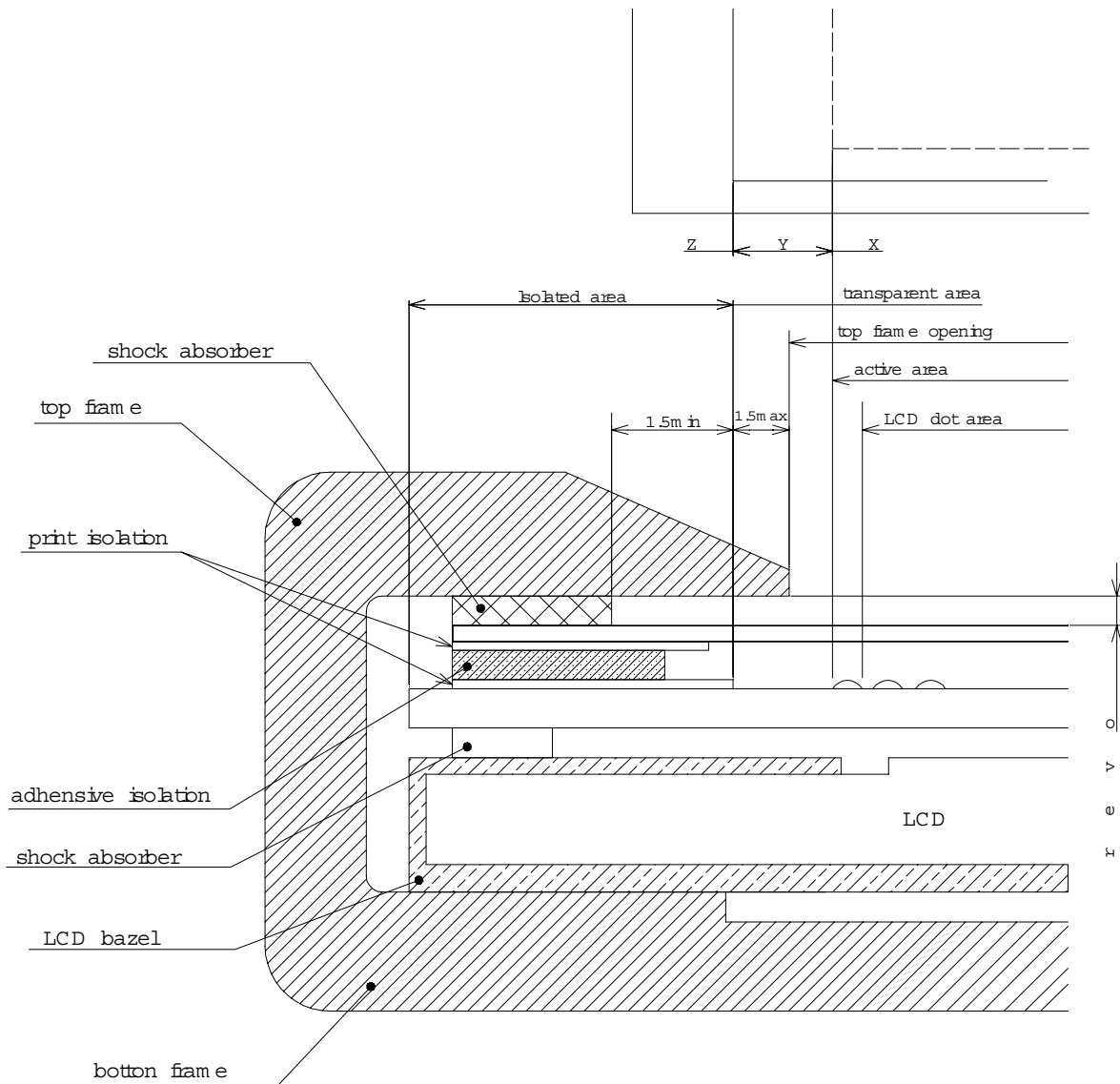

10.3 APPEARANCE SPECIFICATION

(1) LCD APPEARANCE

* IF THE PROBLEM OCCURS ABOUT THIS ITEM THE RESPONSIBLE PERSON OF BOTH PARTY (CUSTOMER AND HITACHI) WILL DISCUSS MORE DETAIL.

| No. | ITEM | CRITERIA | | | APPLIED ZONE |
|--|--|--|---------------------------------|---------------------------------|--------------|
| L C D & T O U C H P A N E L | SCRATCHES | DISTINGUISHED ONE IS NOT ACCEPTABLE (TO BE JUDGE BY HITACHI LMT SAMPLE) | | | A |
| | DENT | SAME AS ABOVE | | | A |
| | WRINKLES IN POLARIZER | SAME AS ABOVE | | | A |
| | BUBBLES | AVERAGE DIAMETER D (mm) | MAXIMUM ACCEPTABLE NUMBER | | A |
| | | D ≤ 0.2 | IGNORE | | |
| | | 0.2 < D ≤ 0.3 | 12 | | |
| | | 0.3 < D ≤ 0.5 | 3 | | |
| | | 0.5 < D | NONE | | |
| | STAINS, FOREIGN MATERIALS DARK SPOT | FILAMENTOUS | | | A, B |
| | | LENGTH L (mm) | WIDTH W (mm) | MAXIMUM ACCEPTABLE NUMBER | |
| | | L ≤ 2.0 | W ≤ 0.03 | IGNORE | |
| | | L ≤ 3.0 | 0.03 < W ≤ 0.05 | 6 | |
| | | L ≤ 2.5 | 0.05 < W ≤ 0.1 | 1 | |
| | | ROUND (DOT SHAPE) | | | A, B |
| | | AVERAGE DIAMETER D (mm) | MAXIMUM ACCEPTABLE NUMBER | MINIMUM SPACE | |
| | | D < 0.2 | IGNORE | - | |
| 0.2 ≤ D < 0.3 | | 10 | 10 mm | | |
| 0.3 ≤ D < 0.4 | | 5 | 30 mm | | |
| 0.4 ≤ D | NONE | - | | | |
| THE TOTAL NUMBER | FILAMENTOUS + ROUND = 10 | | | | |
| THOSE WIPED OUT EASILY ARE ACCEPTABLE | | | A, B | | |
| COLOR TONE | TO BE JUDGE BY HITACHI STANDARD | | | A | |
| COLOR UNIFORMITY | SAME AS ABOVE | | | A | |

| No. | ITEM | CRITERIA | | | | APPLIED ZONE |
|--|--|-------------------------------|---|---------------------------------|------------------|--------------|
| L C D & T O U C H P A N E L | CONTRAST IRREGULARITY (SPOT) | AVERAGE DIAMETER D (mm) | CONTRAST TO BE JUDGED BY HITACHI STANDARD | MAXIMUM ACCEPTABLE NUMBER | MINIMUM SPACE | A |
| | | D ≤ 0.25 | | IGNORE | - | |
| | | 0.25 < D ≤ 0.35 | | 10 | 20mm | |
| | | 0.35 < D ≤ 0.5 | | 4 | 20mm | |
| | | 0.5 < D ≤ 0.7 | | 3 | 50mm | |
| | 0.7 < D | NONE | - | | | |
| | CONTRAST IRREGULARITY (LINE) (A PAIR OF SCRATCH) | WIDTH W (mm) | LENGTH L (mm) | MAXIMUM ACCEPTABLE NUMBER | MINIMUM SPACE | A |
| | | W ≤ 0.25 | L ≤ 1.2 | 2 | 20mm | |
| | | W ≤ 0.2 | L ≤ 1.5 | 3 | 20mm | |
| | | W ≤ 0.15 | L ≤ 2.0 | 3 | 20mm | |
| W ≤ 0.1 | | L ≤ 3.0 | 4 | 20mm | | |
| NOTE (3) | THE WHOLE NUMBER | 6 | | | | |
| RUBBING SCRATCH | TO BE JUDGED BY HITACHI LM STANDARD | | | | | |

(2) CFL BACKLIGHT APPEARANCE

| NO. | ITEM | CRITERIA | | APPLIED ZONE |
|---|--|----------------------------|------------------|--------------|
| C F L | DARK SPOTS WHITE SPOTS FOREIGN MATERIALS (SPOT) | AVERAGE DIAMETER D (nm) | | A |
| | | D ≤ 0.4 | | |
| | | 0.4 < D | | |
| B A C K L I G H T | FOREIGN MATERIALS (LINE) | WIDTH W (nm) | LENGTH L (nm) | A |
| | | W ≤ 0.2 | L ≤ 25 | |
| | | | 2.5 < L | |
| | | 0.2 < W | - | |
| | SCRATCHES | WIDTH W (nm) | LENGTH L (nm) | A |
| | | W ≤ 0.1 | - | |
| | | 0.1 < W ≤ 0.2 | L ≤ 11 | |
| | | | 11 < L | |
| | | 0.2 < W | - | |

NOTE 1 DEFINITION OF AVERAGE DIAMETER (D)

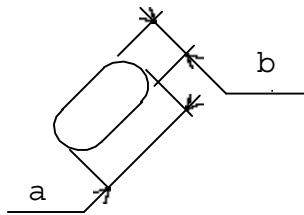

$$D = \frac{a+b}{2}$$

2 DEFINITION OF LENGTH L AND WIDTH (W)

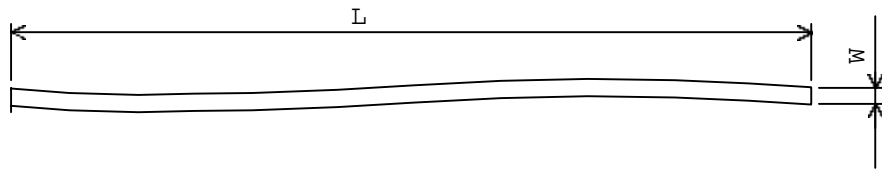

(3) TOUCH PANEL APPEARANCE

(1) EXTERNAL APPEARANCE

| ITEM | | RATINGS | |
|------|-----------------------|--------------------------------------|--|
| 1 | DOT FOREIGN PARTICLES | AVERAGE DIAMETER (D) | SPECIFICATION |
| | | $D \leq 0.2\text{mm}$ | NOT COUNTED |
| | | $0.2\text{mm} < D \leq 0.3\text{mm}$ | 2 OR LESS (WITHIN $\phi 50\text{mm}$) |
| | | $0.3\text{mm} < D$ | 0 |

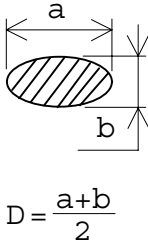

$D = \frac{a+b}{2}$

| | | | |
|-----------------------|---|---------------------------------------|--|
| 2 | LINEAR FOREIGN PARTICLES , SCRATCHES | BREADTH (W) | SPECIFICATION |
| | | $W < 0.05\text{mm}$ | NOT COUNTED |
| | | $0.05\text{mm} \leq W < 0.1\text{mm}$ | $L \geq 5\text{mm}$:NG |
| | | | $L < 5\text{mm}$: 2 OR LESS (WITHIN $\phi 50\text{mm}$) |
| $0.1\text{mm} \leq W$ | DOT | | |

| | | | |
|---|------------|---------------------|--|
| 3 | UNCLEANNES | NO CONSPICUOUS DIRT | |
|---|------------|---------------------|--|

| | | |
|---|----------------|---|
| 4 | GLASS CHIPPING | $a < 5, b < 2, c \leq t$ (t= GLASS THICKNESS) |
| | | NONE OF THE ABOVE FIGURES MAY BE EXCEEDED. THE NUMBER OF CHIPPED AREAS DOES NOT NEED TO BE CONSIDERED. (SAME AS CORNER) |

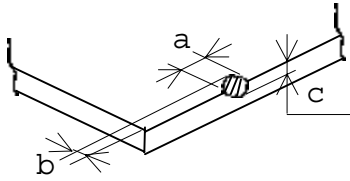

| | | |
|---|-----------------|--|
| 5 | CORNER CHIPPING | $a < 5, b < 2, c \leq t$ (t=GLASS THICKNESS) |
|---|-----------------|--|

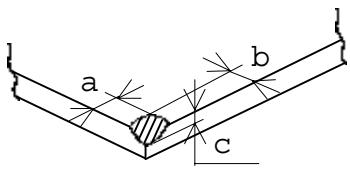

| | | | |
|---|-------------|---|--|
| 6 | GLASS CRACK | NO CRACKS ARE ALLOWED .NO CHIPPING TO TOUCH WITH CIRCUIT. | |
|---|-------------|---|--|

| | | | |
|---|-------------------------------|--|--|
| 7 | WAVINESS OF TOP SHEET SURFACE | FLUORESCENT LAMPS MUST NOT APPEAR DISTORTED. | |
|---|-------------------------------|--|--|

| | | | |
|---|-------------|---|--|
| 8 | NEWTON RING | NO UNUSUAL INTERFERENCE FRINGE MUST SHOW WHEN SEEN THROUGH THE TOP SURFACE SHEET. | |
|---|-------------|---|--|

THE SPECIFICATIONS MENTIONED ABOVE APPLY TO TRANSPARENT AREA ONLY. APPLICATION TO OTHER AREAS ARE WAIVED UNLESS CONCERN FOR MECHANICAL OR ELECTRICAL PERFORMANCE DEVELOPS. (GLASS CHIPPING IS EXCEPTED)

② CIRCUIT PATTERN

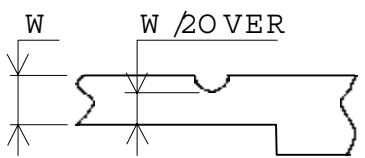
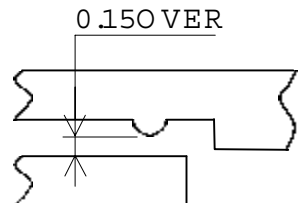
| ITEM | RATINGS |
|--------------------------------|--|
| MNMUM CIRCUIT PATTERN WIDTH |  |
| MNMUM CIRCUIT PATTERN GAP |  |

11. PRECAUTION IN DESIGN

11.1 MOUNTING METHOD

SINCE THE MODULE IS SO CONSTRUCTED AS TO BE FIXED BY UTILIZING FITTING HOLES IN THE PRINTED CIRCUIT BOARD AS SHOWN BELOW, IT IS NECESSARY TO TAKE CONSIDERATION THE FOLLOWING ITEMS ON ATTACHMENT TO A FRAME.

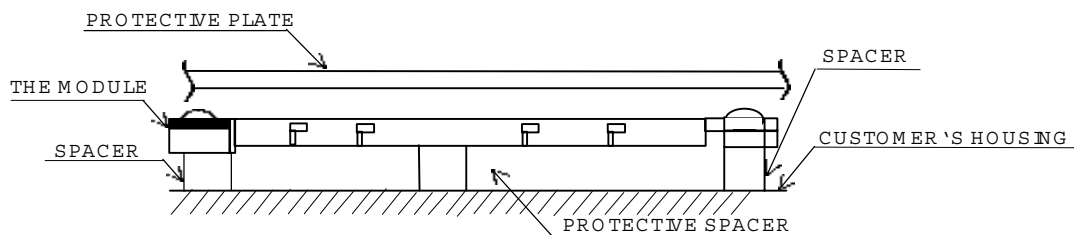

- (1) USE OF PROTECTIVE PLATE MADE OF AN ACRYLIC PLATE, ETC, IN ORDER TO PROTECT A POLARIZER AND LC CELL.
- (2) TO PREVENT THE MODULE COVER FROM BEING PRESSED, THE SPACERS BETWEEN THE MODULE AND THE FITTING PLATES SHOULD BE LONGER THAN 0.5mm.
- (3) WE RECOMMEND YOU TO USE PROTECTIVE SPACER AS FIGURE FOR PROTECTING LCD MODULE FROM ANY KIND OF SHOCK TO YOUR SET.

11.2 LC DRIVING VOLTAGE (VEE) AND VIEWING ANGLE RANGE.

SETTING V₀ OUT OF THE RECOMMENDED CONDITION WILL BE A CAUSE FOR A CHANGE OF VIEWING ANGLE RANGE.

11.3 CAUTION AGAINST STATIC CHARGE

AS THIS MODULE IS PROVIDED WITH CMOS LSI, THE CARE TO TAKE SUCH A PRECAUTION AS TO GROUNDING THE OPERATOR'S BODY IS REQUIRED WHEN HANDLING IT.

11.4 POWER ON SEQUENCE

INPUT SIGNALS SHOULD NOT BE APPLIED TO LCD MODULE BEFORE POWER SUPPLY VOLTAGE IS APPLIED AND REACHES TO SPECIFIED VOLTAGE (VDD).

IF ABOVE SEQUENCE IS NOT KEPT, CMOS LSIS OF LCD MODULES MAY BE DAMAGED DUE TO LATCH UP PROBLEM.

11.5 PACKAGING

- (1) NO. LEAVING PRODUCTS IS PREFERABLE IN THE PLACE OF HIGH HUMIDITY FOR A LONG PERIOD OF TIME. FOR THEIR STORAGE IN THE PLACE WHERE TEMPERATURE IS 35° OF HIGHER, SPECIAL CARE TO PREVENT THEM FROM HIGH HUMIDITY IS REQUIRED. A COMBINATION OF HIGH TEMPERATURE AND HIGH HUMIDITY MAY CAUSE THEM POLARIZATION DEGRADATION AS WELL AS BUBBLE GENERATION AND POLARIZER PEEL-OFF. PLEASE KEEP THE TEMPERATURE AND HUMIDITY WITHIN THE SPECIFIED RANGE FOR USE AND STORING.

- (2) SINCE UPPER POLARIZERS AND LOWER ALUMINUM PLATES TEND TO BE EASILY DAMAGED, THEY SHOULD BE HANDLED WITH FULL CARE SO AS NOT TO GET THEM TOUCHED, PUSHED OR RUBBED BY A PIECE OF GLASS. TWEEZERS AND ANYTHING ELSE WHICH ARE HARDER THAN A PENCIL LEAD 3H.
- (3) AS THE ADHESIVES USED FOR ADHERING UPPER/LOWER POLARIZERS AND ALUMINUM PLATES ARE MADE OF ORGANIC SUBSTANCES WHICH WILL BE DETERIORATED BY A CHEMICAL REACTION WITH SUCH CHEMICALS AS ACETONE, TOLUENE ETHANOLE AND ISOPROPYLALCOHOL. THE FOLLOWING SOLVENTS ARE RECOMMENDED FOR USE:
 NORMAL HEXANE
 PLEASE CONTACT US WHEN IT IS NECESSARY FOR YOU TO USE CHEMICALS OTHER THAN THE ABOVE.
- (4) LIGHTLY WIPE TO CLEAN THE DIRTY SURFACE WITH ABSORBENT COTTON WASTE OR OTHER SOFT MATERIAL LIKE CHAMOIS, SOAKED IN THE CHEMICALS RECOMMENDED WITHOUT SCRUBBING IT HARDLY TO PREVENT THE DISPLAY SURFACE FROM DAMAGE AND KEEP THE APPEARANCE IN GOOD STATE, IT IS SUFFICIENT, IN GENERAL, TO WIPE IT WITH ABSORBENT COTTON.
- (5) IMMEDIATELY WIPE OFF SALIVA OR WATER DROP ATTACHED ON THE DISPLAY AREA BECAUSE ITS LONG PERIOD ADHERENCE MAY CAUSE DEFORMATION OR FADED COLOR ON THE SPOT.
- (6) FOGY DEW DEPOSITED ON THE SURFACE AND CONTACT TERMINALS DUE TO COLDNESS WILL BE A CAUSE FOR POLARIZER, DAMAGE STAIN AND DIRT ON PRODUCT WHEN NECESSARY TO TAKE OUT THE PRODUCTS FROM SOME PLACE AT LOW TEMPERATURE FOR TEST, ETC. IT IS REQUIRED FOR THEM TO BE WARMED UP IN A CONTAINER ONCE AT THE TEMPERATURE HIGHER THAN THAT OF ROOM.
- (7) TOUCHING THE DISPLAY AREA AND CONTACT TERMINALS WITH BARE HANDS AND CONTAMINATING THEM ARE PROHIBITED, BECAUSE THE STAIN ON THE DISPLAY AREA AND POOR INSULATION BETWEEN TERMINALS ARE OFTEN CAUSED BY BEING TOUCHED BY BARE HANDS. (THERE ARE SOME COSMETICS DETRIMENTAL TO POLARIZERS.)
- (8) IN GENERAL THE QUALITY OF GLASS IS FRAGILE SO THAT IT TENDS TO BE CRACKED OR CHIPPED IN HANDLING, SPECIALLY ON ITS PERIPHERY PLEASE BE CAREFUL NOT TO GIVE IT SHARP SHOCK CAUSED BY DROPPING DOWN ETC.

11.6 CAUTION FOR OPERATION

- (1) IT IS AN INDISPENSABLE CONDITION TO DRIVE LCD'S WITHIN THE SPECIFIED VOLTAGE LIMIT SINCE THE HIGHER VOLTAGE THAN THE LIMIT CAUSES THE SHORTER LCD LIFE AN ELECTROCHEMICAL REACTION DUE TO DIRECT CURRENT CAUSES LCD'S UNDESIRABLE DETERIORATION, SO THAT THE USE OF DIRECT CURRENT DRIVER SHOULD BE AVOIDED.
- (2) RESPONSE TIME WILL BE EXTREMELY DELAYED AT LOWER TEMPERATURE THAN THE OPERATING TEMPERATURE RANGE AND ON THE OTHER HAND AT HIGHER TEMPERATURE LCD'S SHOW DARK BLUE COLOR IN THEM HOWEVER THOSE PHENOMENA DO NOT MEAN MALFUNCTION OR OUT OF ORDER WITH LCD'S WHICH WILL COME BACK IN THE SPECIFIED OPERATING TEMPERATURE RANGE.
- (3) IF THE DISPLAY AREA IS PUSHED HARD DURING OPERATION, SOME FONT WILL BE ABNORMALLY DISPLAY BUT IT RESUMES NORMAL CONDITION AFTER TURNING OFF ONCE.
- (4) A SLIGHT DEW DEPOSITING ON TERMINALS IS A CAUSE FOR ELECTROCHEMICAL REACTION RESULTING IN TERMINAL OPEN CIRCUIT. USAGE UNDER THE RELATIVE CONDITION OF 40°C 50% RH OR LESS IS REQUIRED.
- (5) SINCE STN-LCD IS SENSITIVE FOR HEAT PLEASE CONSIDER THE HEAT PROTECTION FROM ANY HEAT SOURCES LIKE INVERTER, DC/DC CONVERTER, CPU AND SO ON.

11.7 STORAGE

IN CASE OF STORING FOR A LONG PERIOD OF TIME (FOR INSTANCE, FOR YEARS) FOR THE PURPOSE OF REPLACEMENT USE, THE FOLLOWING WAYS ARE RECOMMENDED.

- (1) STORAGE IN A POLYETHYLENE BAG WITH THE OPENING SEALED SO AS NOT TO ENTER FRESH AIR OUTSIDE IN IT AND WITH NO DESICCANT.
- (2) PLACING IN A DARK PLACE WHERE NEITHER EXPOSURE TO DIRECT SUNLIGHT NOR LIGHT IS, KEEPING TEMPERATURE IN THE RANGE FROM 0°C TO 35°C.
- (3) STORING WITH NO TOUCH ON POLARIZER SURFACE BY ANYTHING ELSE. (IT IS RECOMMENDED TO STORE THEM AS THEY HAVE BEEN CONTAINED IN THE INNER CONTAINER AT THE TIME OF DELIVERY FROM US.)

11.8 SAFETY

- (1) IT IS RECOMMENDABLE TO CRASH DAMAGED OR UNNECESSARY LCD'S INTO PIECES AND WASH OFF LIQUID CRYSTAL BY EITHER OF SOLVENTS SUCH AS ACETONE AND ETHANOL, WHICH SHOULD BE BURNED UP LATER.
- (2) WHEN ANY LIQUID LEAKED OUT OF A DAMAGED GLASS GELL COMES IN CONTACT WITH YOUR HANDS, PLEASE WASH IT OFF WELL WITH SOAP AND WATER.

12. DESIGNATION OF LOT MARK

12.1 LOT MARK

LOT MARK IS CONSISTED OF 4 LIGHT FOR PRODUCTION LOT 6 OR 7 DIGITS FOR PRODUCTION CONTROL.

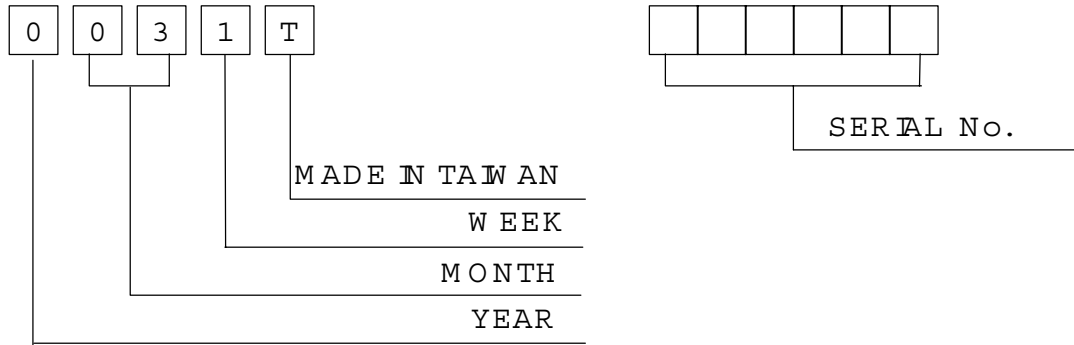

| YEAR | FIGURE IN LOT MARK |
|------|--------------------|
| 1999 | 9 |
| 2000 | 0 |
| 2001 | 1 |
| 2002 | 2 |
| 2003 | 3 |

| MONTH | FIGURE IN LOT MARK | MONTH | FIGURE IN LOT MARK |
|-------|--------------------|-------|--------------------|
| JAN. | 01 | JULY. | 07 |
| FEB. | 02 | AUG. | 08 |
| MAR. | 03 | SEPT. | 09 |
| APR. | 04 | OCT. | 10 |
| MAY. | 05 | NOV. | 11 |
| JUNE. | 06 | DEC. | 12 |

| WEEK (DAY IN CALENDAR) | FIGURE IN LOT MARK |
|------------------------|--------------------|
| 01~07 | 1 |
| 08~14 | 2 |
| 15~21 | 3 |
| 22~28 | 4 |
| 29~31 | 5 |

12.2 Revision

| REV. No. | ITEM | LOT No. |
|----------|-----------------------------|---------|
| - | | |
| 7 | CHANGE T/P AND CFL, SMK T/P | |
| 8 | Fujitsu T/P | |

12.3 LOCATION OF LOT MARK : ON THE LABEL ATTACHED ON THE BACK SIDE OF LCM

EXAMPLE :

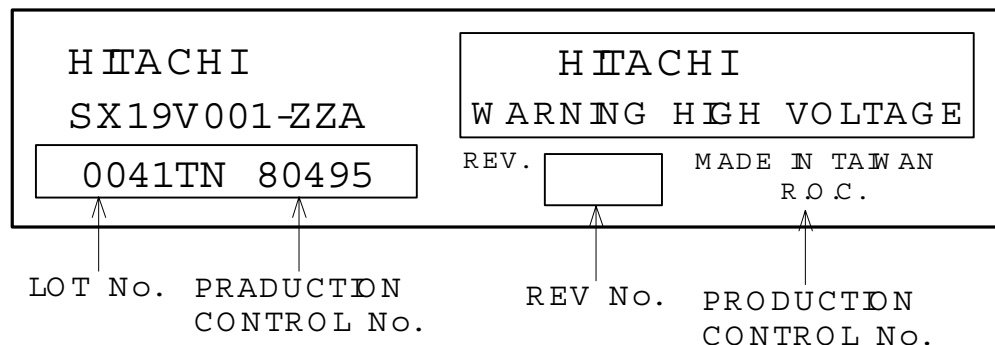

13.PRECIPTIN FOR USE

- (1) A LMI SAMPLE SHOULD BE PROVIDED BY THE BOTH PARTIES ON AN OCCASION WHEN THE BOTH PARTIES AGREED ITS NECESSITY. JUDGMENT BY A LMI SAMPLE SHALL TAKE EFFECT AFTER THE LMI SAMPLE HAS BEEN ESTABLISHED AND CONFIRMED BY THE BOTH PARTIES.
- (2) ON THE FOLLOWING OCCASIONS, THE HANDLING OF THE PROBLEM SHOULD BE DECDED THROUGH DISCUSSION AND AGREEMENT BETWEEN RESPONSBLE PERSONS OF THE BOTH PARTIES.
 - (1) WHEN A QUESTION IS ARISEN IN THE SPECIFICATONS.
 - (2) WHEN A NEW PROBLEM IS ARISEN WHICH IS NOT SPECIFIED IN THIS SPECIFICATONS.
 - (3) WHEN AN INSPECTON SPECIFICATONS CHANGE OR OPERATING CONDITON CHANGE IN CUSTOMER IS REPORTED TO HITACHI, AND SOME PROBLEM IS ARISEN IN THIS SPECIFICATON DUE TO THE CHANGE.
 - (4) WHEN A NEW PROBLEM IS ARISEN AT THE CUSTOMER'S OPERATING SET FOR SAMPLE EVALUATION IN THE CUSTOMER SITE.
- (3) REGARDING THE TREATMENT FOR MAINTENANCE AND REPAORING ,BOTH PARTES WILL DISCUSS IT IN SX MONTHS LATER AFTER LATEST DELIVERY OF THIS PRODUCT.

THE PRECAUTION THAT SHOULD BE OBSERVED WHEN HANDLING LCM HAVE BEEN EXPLAND ABOVE. IF ANY POINTS ARE UNCLEAR OR IF YOU HAVE ANY REQUESTS,PLEASE CONTACT HITACHI.